



UART & SPI

Lecture 5



UART & SPI

used by RP2350 and STM32U545RE

- Direct Memory Access
- Buses
 - Universal Asynchronous Receiver and Transmitter
 - Serial Peripheral Interface
- Analog and Digital Sensors

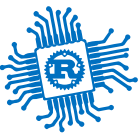

DMA

Direct Memory Access

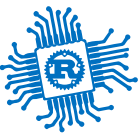

Bibliography

for this section

1. **Raspberry Pi Ltd**, *RP2350 Datasheet*

- Chapter 12 - *Peripherals*
 - Chapter 16.6 - *DMA*

2. **STMicroelectronics**, *STM32U545RE Reference Manual*

- Chapter 17 - *General purpose direct memory access controller*

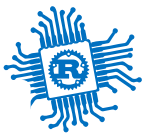

DMA

- offloads the MCU from doing **memory to memory** operations
 - due to MMIO, usually implies **transfers from and to peripherals**
 - raises an interrupt when a transfer is done
- ⚠ DMA does not know about the data stored in cache.
- for chips that use cache
 - the DMA buffer's memory region has to be set manually to *nocache* (if MCU knows)
 - or, the cache has to be flushed before and, possibly after, a DMA transfer

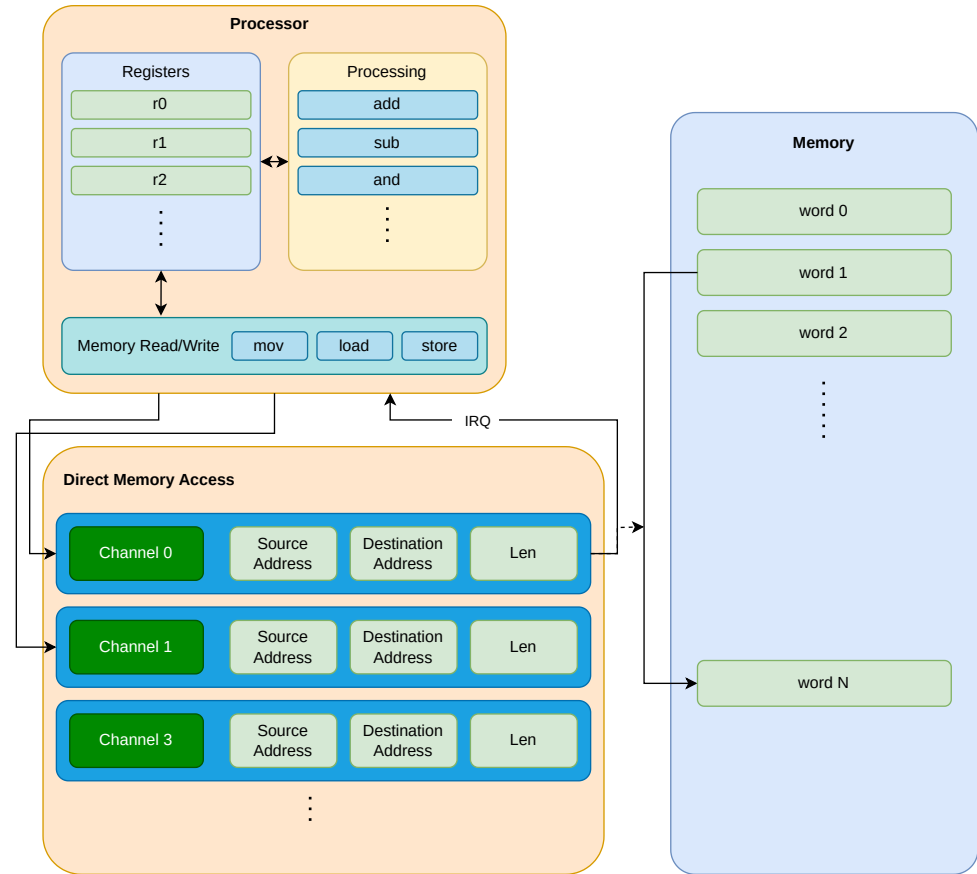



RP2

- 12 (RP2040) channels or 16 (RP2350) channels
- Transfers
 - Memory to Peripheral
 - Peripheral to Memory
 - Memory to Memory

STM32U545RE

- 16 General Purpose DMA (GPDMA) channels
- 4 Low Power DMA (LPDMA) channels
- 4 priority levels
- Transfers
 - Memory to Peripheral
 - Peripheral to Memory
 - Memory to Memory
 - Peripheral to Peripheral

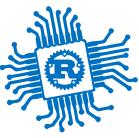

UART

Universal Asynchronous Receiver and Transmitter

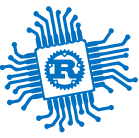

Bibliography

for this section

1. **Raspberry Pi Ltd**, *RP2350 Datasheet*
 - Chapter 12 - *Peripherals*
 - Chapter 12.1 - *UART*
2. **STMicroelectronics**, *STM32U545RE Reference Manual*
 - Chapter 66 - *Universal synchronous/asynchronous receiver transmitter*
3. **Paul Denisowski**, *Understanding Serial Protocols*
4. **Paul Denisowski**, *Understanding UART*



UART

aka serial port

- connects **two devices**
- uses two **independent** wires
 - *TX* - transmission wire
 - *RX* - reception wire
- cross-connected

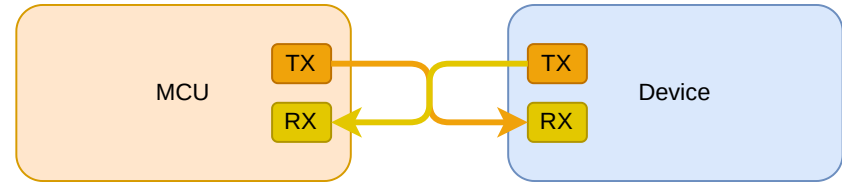

Transmission example

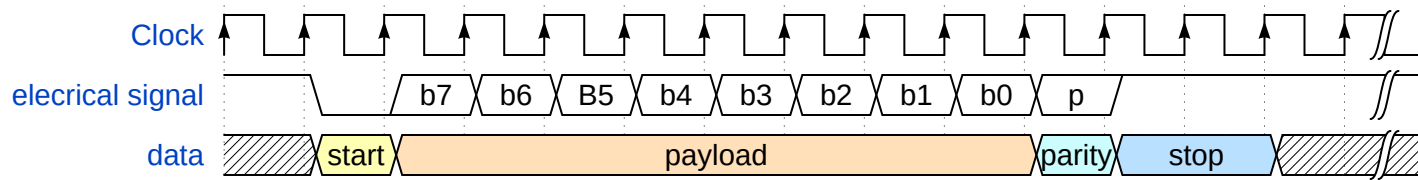

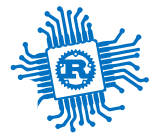

UART Device

properties

bits the number of bits in the payload, between 5 and 9

parity add or not the parity bit

stop the number of stop bits to add, 1 or 2

baud rate number of elements sent per s, most used **9600** or **115200**

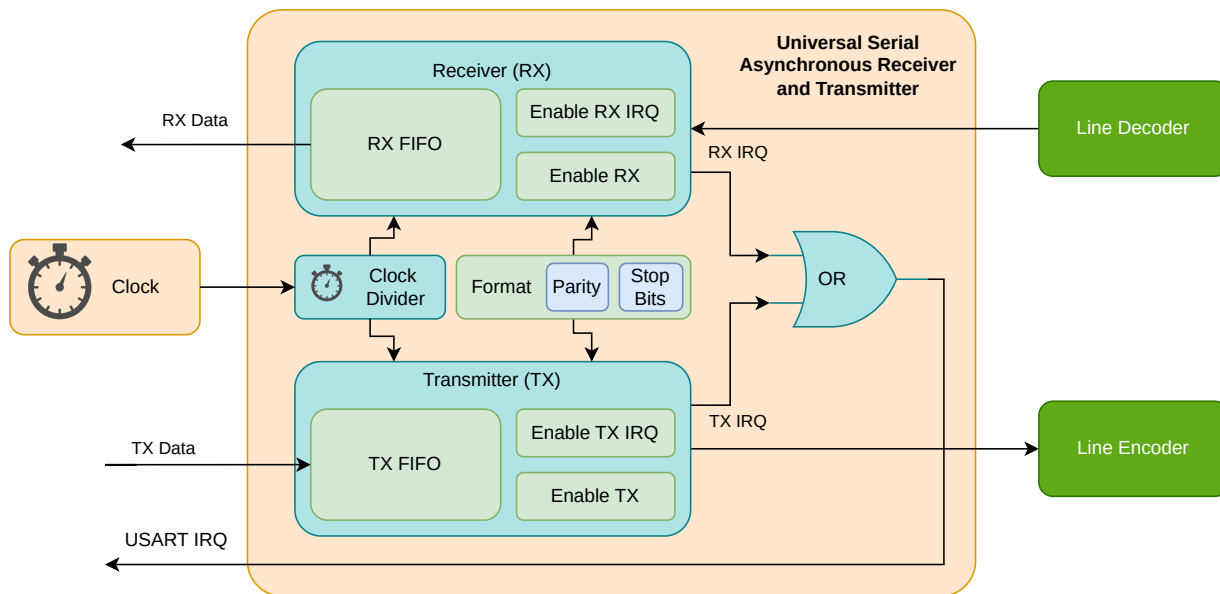

$$baud_{rate} = \frac{f_{clock}}{divider \times (1 + payload_{bits} + parity_{bits} + stop_{bits})}$$



UART Device

types

- **TTL** - *Transistor Transistor Logic* connects devices at 0 - 3.3V or 0 - 5V, used for short cables and jumper wires
- **RS232** - used for external connections and longer cables, uses -12V to 12V.
- **RS485** - industrial, uses differential voltage

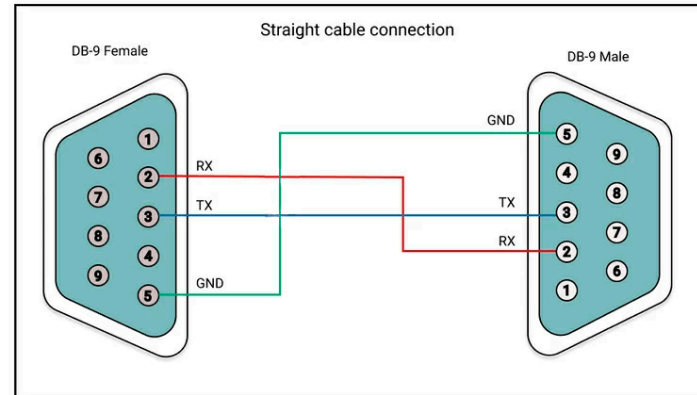
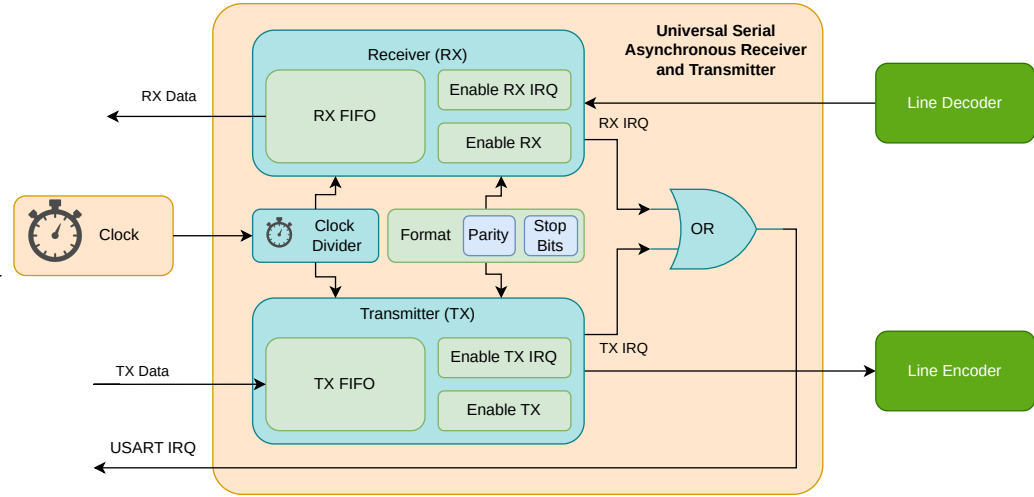



Receiver

RX part of the serial port

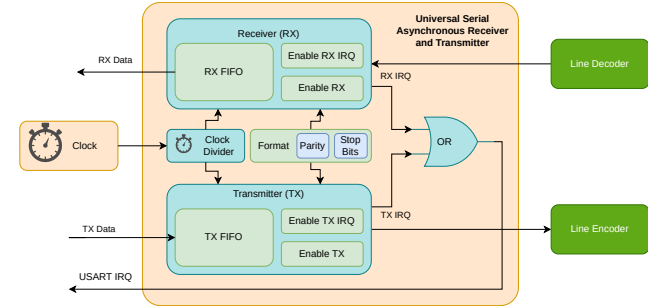
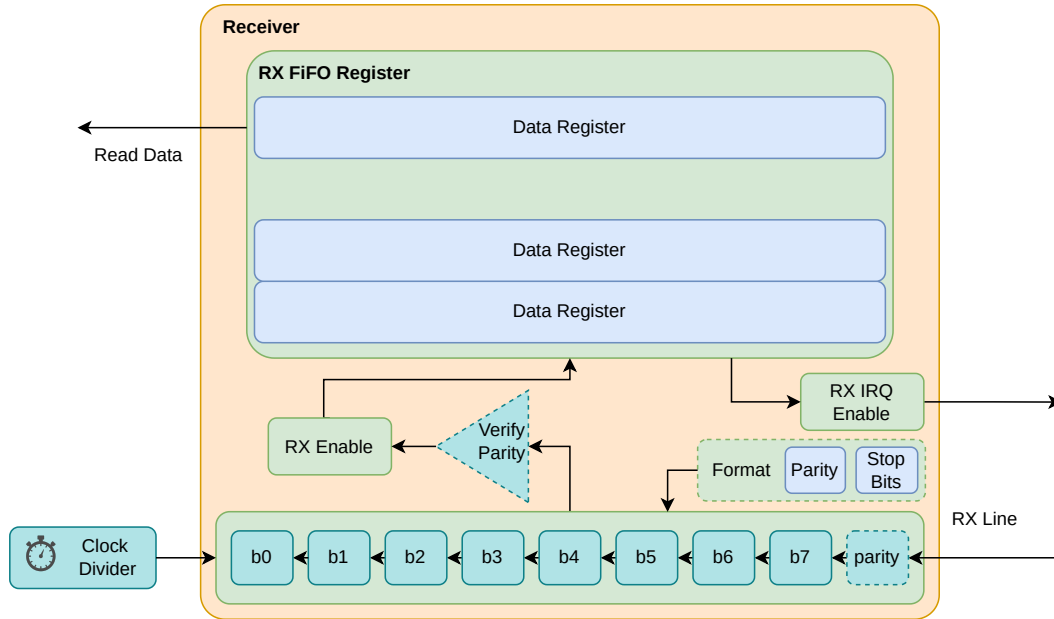

- *Shift Register* to read **serially every bit**
- Triggers an interrupt
 - when data was received
 - (optional) when FIFO is half full
 - (optional) when FIFO is full
- FIFO is optional
 - may have a capacity of 1



Transmitter

TX part of the serial port

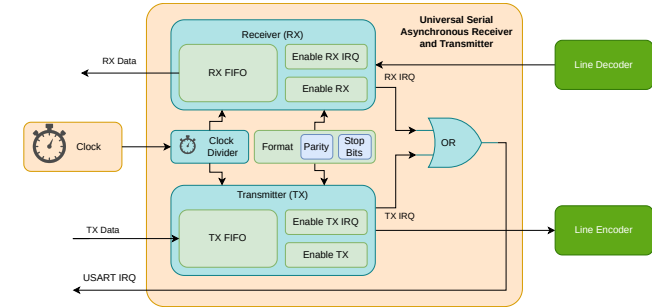
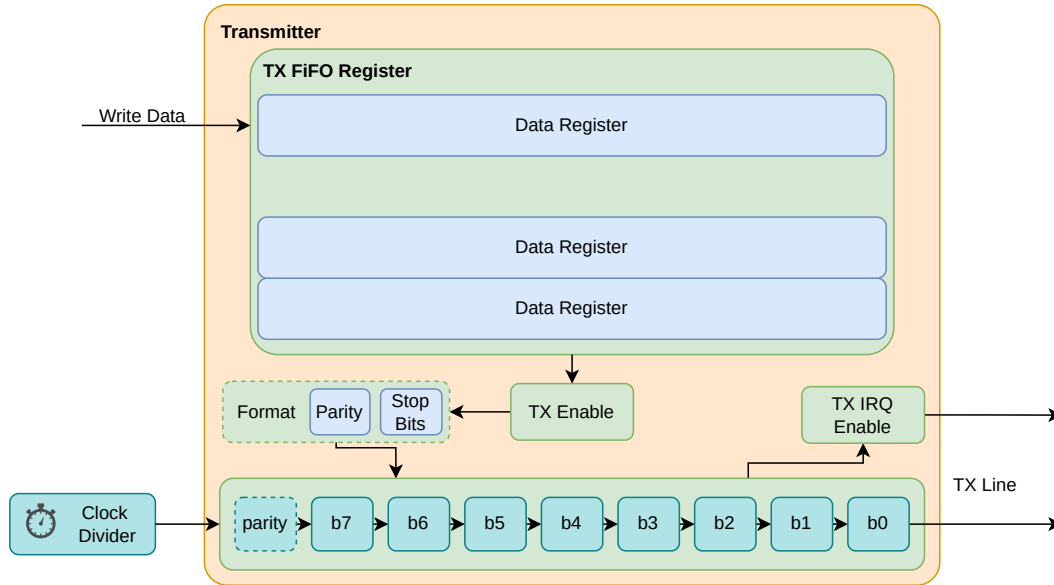

- *Shift Register* to output **serially every bit**
- Triggers an interrupt
 - when data was sent
 - (optional) when FIFO is half empty
 - (optional) when FIFO is empty
- FIFO is optional
 - may have a capacity of 1

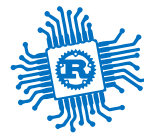

Transmission Examples

Setup	Payload	Parity	Stop
8N1	8 bits	no	1 bit
8P2	8 bits	yes	2 bits
9P1	9 bits	yes	1 bit

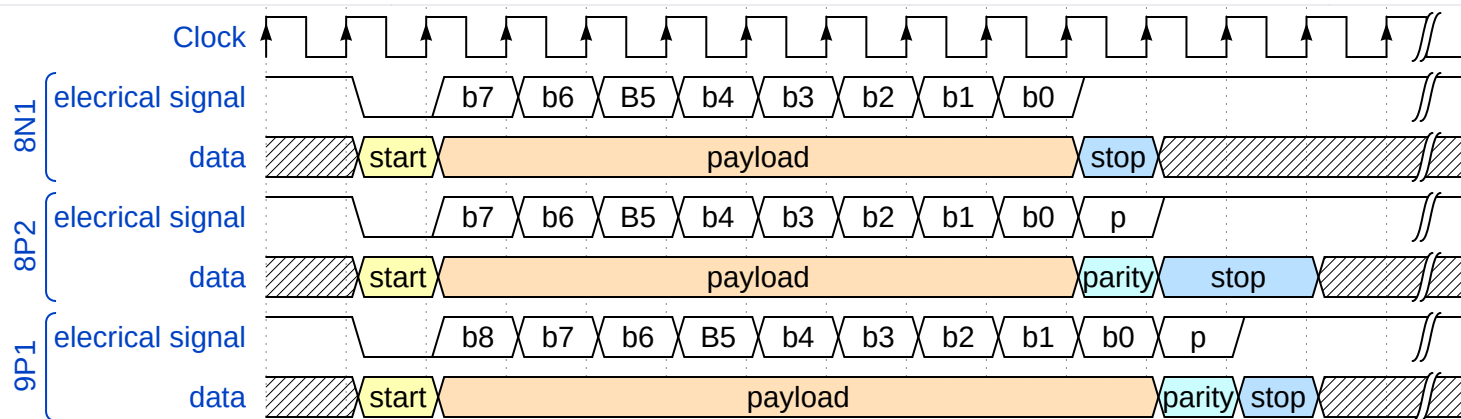

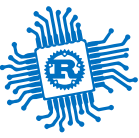

Successive Transmission

using the 8N1 data format

Back to back

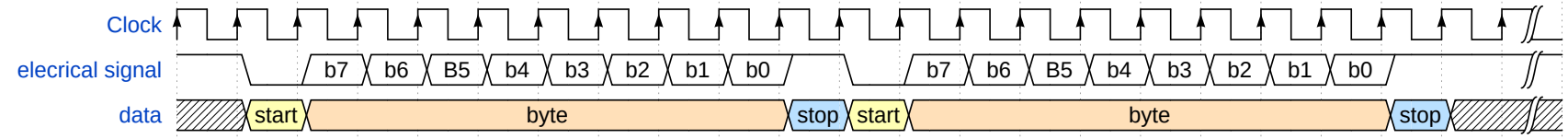

With delay

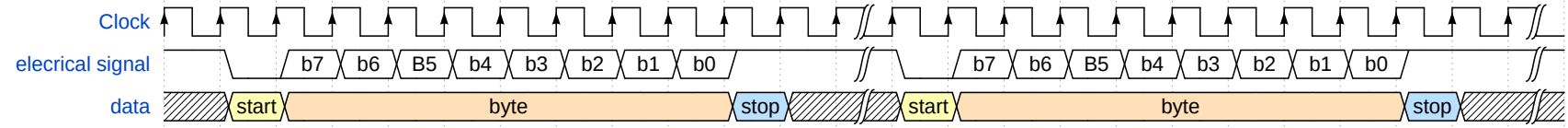



Facts

Transmission	<i>duplex</i>	data can be sent in both directions at the same time
Clock	<i>independent</i>	there is no clock sent between the two devices, the receiver has to synchronize its clock with the transmitter to be able to correctly read the received data
Wires	<i>RX / TX</i>	one receive wire, one transmit wire, independent of each other
Devices	<i>2</i>	a receiver and a transmitter
Speed	<i>115 KB/s</i>	usually a maximum baud rate of 115200 is used

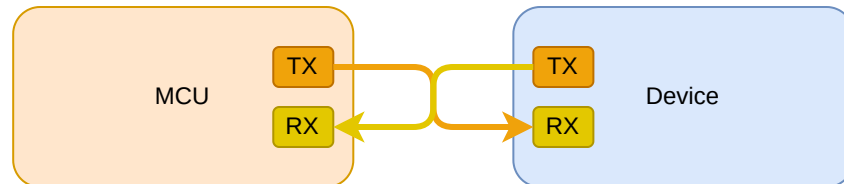

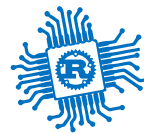

Usage

- print debug information
- device console
- RP2350 has two USART devices
- STM32U545RE has two full (UASRT1, USART3), two basic (UART4, UART5) and one low power (LPUART1)

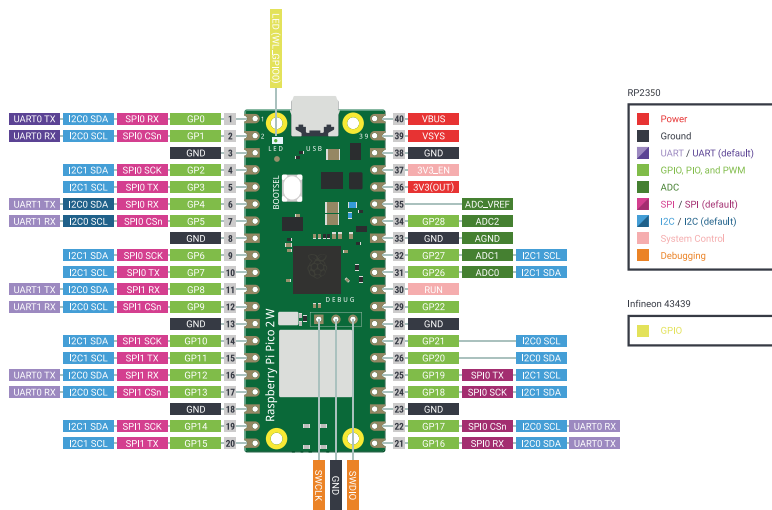



Synchronous Embassy API

for RP2350

```
pub struct Config {  
    pub baudrate: u32,  
    pub data_bits: DataBits,  
    pub stop_bits: StopBits,  
    pub parity: Parity,  
    // ...  
}
```

```
pub enum DataBits {  
    DataBits5,  
    DataBits6,  
    DataBits7,  
    DataBits8,  
}
```

```
pub enum StopBits {  
    STOP1,  
    STOP2,  
}
```

```
pub enum Parity {  
    ParityNone,  
    ParityEven,  
    ParityOdd,  
}
```

```
1 use embassy_rp::uart::Config as UartConfig;  
2 let config = UartConfig::default();  
3  
4 // use UART0, Pins 0 and 1  
5 let mut uart = uart::Uart::new_blocking(p.UART0, p.PIN_0, p.PIN_1, config);  
6 // write  
7 uart.blocking_write("Hello World!\r\n".as_bytes());  
8  
9 // read 5 bytes  
10 let mut buf = [0; 5];  
11 uart.blocking_read(&mut buf);
```



Synchronous Embassy API

for STM32U545RE

```
pub struct Config {  
    pub baudrate: u32,  
    pub data_bits: DataBits,  
    pub stop_bits: StopBits,  
    pub parity: Parity,  
    // ...  
}
```

```
pub enum DataBits {  
    DataBits7,  
    DataBits8,  
    DataBits9,  
}
```

```
pub enum StopBits {  
    STOP1,  
    STOP0P5,  
    STOP2,  
    STOP1P5  
}
```

```
pub enum Parity {  
    ParityNone,  
    ParityEven,  
    ParityOdd,  
}
```

```
1 use embassy_stm32::usart::Config as UartConfig;  
2 let config = UartConfig::default();  
3  
4 // use UART1, Pins PA10 and PA9  
5 let mut uart = Uart::new_blocking(p.USART1, p.PA10, p.PA9, config).unwrap();  
6 // write  
7 uart.blocking_write("Hello World!\r\n".as_bytes());  
8  
9 // read 5 bytes  
10 let mut buf = [0; 5];  
11 uart.blocking_read(&mut buf);
```



Asynchronous Embassy API

for RP2350

```
1 use embassy_rp::uart::Config as UartConfig;
2
3 bind_interrupts!(struct Irqs {
4     UART0_IRQ => BufferedInterruptHandler<UART0>;
5 });
6
7 let config = UartConfig::default();
8
9 // use UART0, Pins 0 and 1
10 let mut uart = uart::Uart::new(p.UART0, p.PIN_0, p.PIN_1, Irqs, p.DMA_CH0, p.DMA_CH1, config);
11
12 // write
13 uart.write("Hello World!\r\n".as_bytes()).await;
14
15 // read 5 bytes
16 let mut buf = [0; 5];
17 uart.read(&mut buf).await;
```



Asynchronous Embassy API

for STM32U545RE

```
1 use embassy_stm32::usart::Config as UartConfig;
2
3 bind_interrupts!(struct Irqs {
4     USART1 => usart::InterruptHandler<peripherals::USART1>;
5 });
6
7 let config = UartConfig::default();
8
9 // use USART3, Pins PA10 and PA9
10 let mut uart = Uart::new(p.USART1, p.PA10, p.PA9, Irqs, p.GPDMA1_CH0, p.GPDMA1_CH1, config).unwrap();
11
12 // write
13 uart.write("Hello World!\r\n".as_bytes()).await;
14
15 // read 5 bytes
16 let mut buf = [0; 5];
17 uart.read(&mut buf).await;
```



SPI

Serial Peripheral Interface

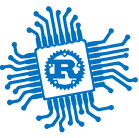

Bibliography

for this section

1. **Raspberry Pi Ltd**, *RP2350 Datasheet*
 - Chapter 12 - *Peripherals*
 - Chapter 12.3 - *SPI*
2. **STMicroelectronics**, *STM32U545RE Reference Manual*
 - Chapter 68 - *Serial Peripheral Interface*
3. **Paul Denisowski**, *Understanding SPI*

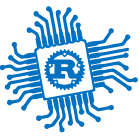

SPI

a.k.a *spy*

- Used for communication between integrated circuits
- Sensors usually expose an *SPI* and an *I2C* interface
- Two device types:
 - *main* (master) - controls the communication (usually MCU)
 - *sub* (slave) - receive and transmit data when the *main* requests (usually the sensor)

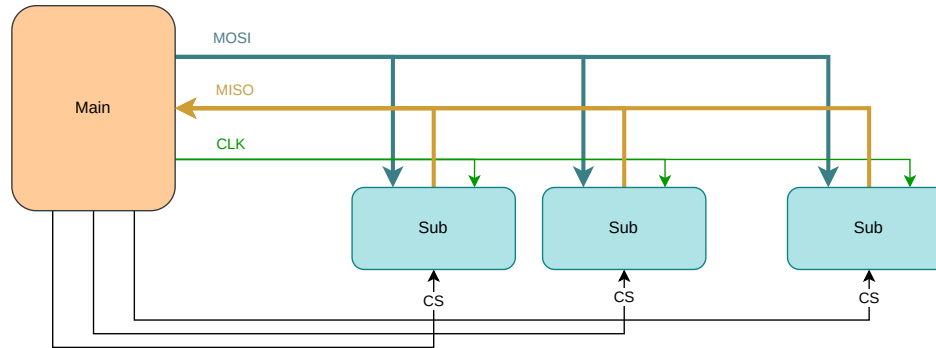



Wires

3 + n

- **MOSI** - **M**ain **O**ut **S**ub **I**n - carries data from the **main** to the **subs**
- **MISO** - **M**ain **I**n **S**ub **O**ut - carries data from the active **sub** to the **main**
- **CLK** - Clock - the clock signal generated by the **main**, **subs** sample and write data to the bus only on the clock edge
- **CS*** - **C**hip **S**elect - not actually part of SPI, one wire / sub, activates **one sub at a time**
 - inactive subs have to disconnect from the **MOSI** and **MISO** lines

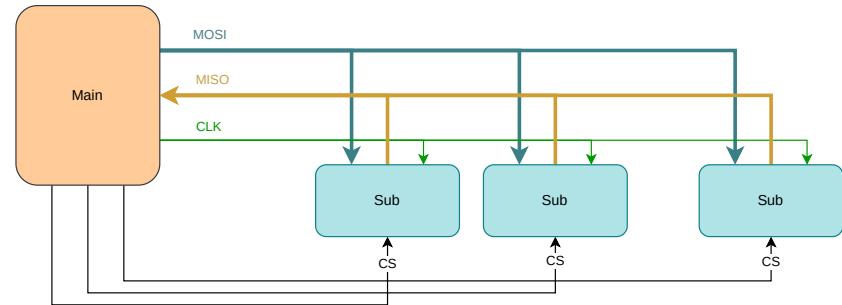
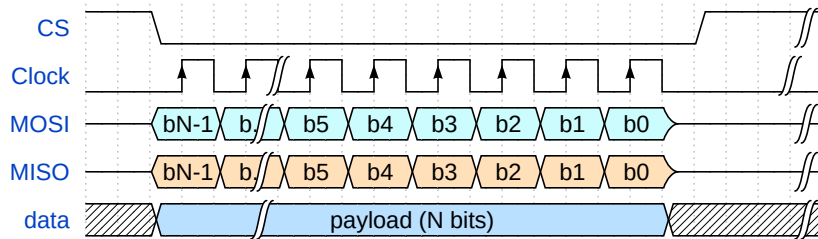



Transmission Example

1. **main** activates the sub device
 - sets the **CS** signal to **LOW**
2. at the same time
 - **main** puts the first bit on the **MOSI** line
 - **sub** puts the first bit on the **MISO** line
3. **main** starts the clock
4. at the *rising edge*
 - **main** reads the data from the **MISO** line
 - **sub** reads the data from the **MOSI** line
5. on the *falling edge*
 - **main** puts the next bit on the **MOSI** line
 - **sub** puts the next bit on the **MISO** line
6. repeat 4 and 5 until **main** decides to stop the clock

SPI Signals

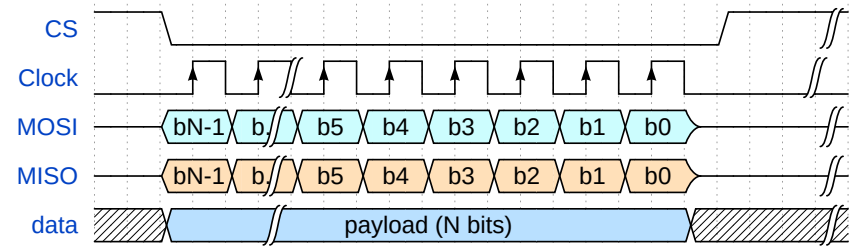

SPI Network

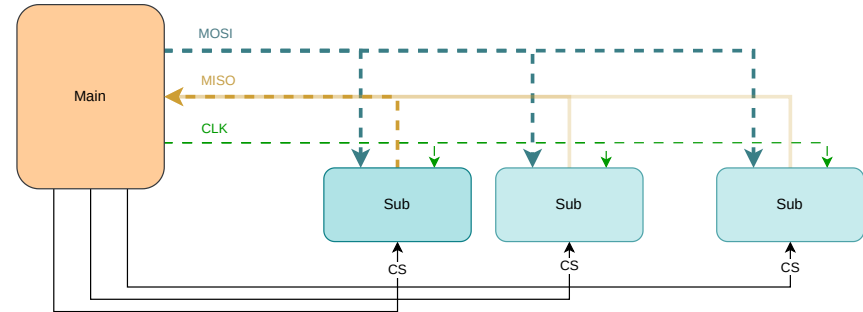



SPI Modes

when data is read and written

Mode	CPOL	CPHA
0	0	0
1	0	1
2	1	0
3	1	1

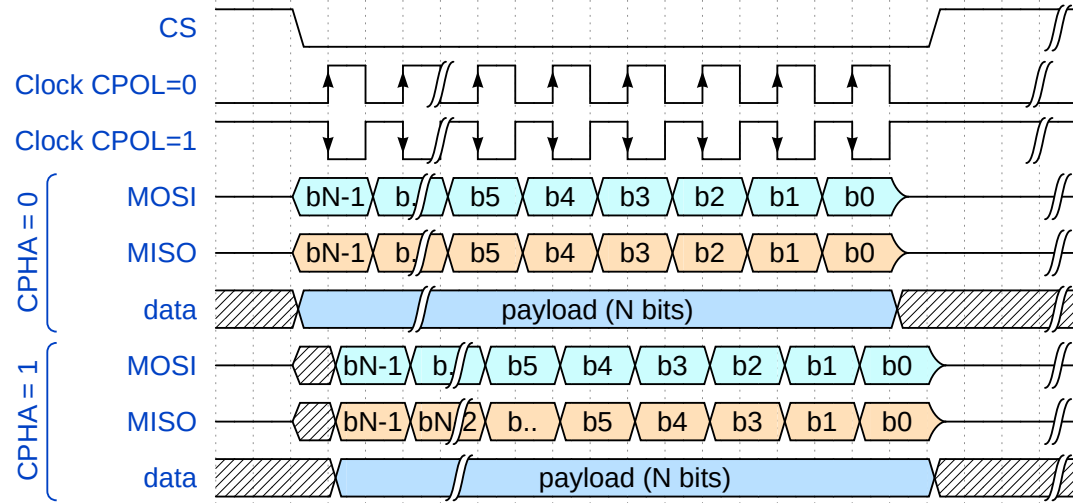

The idle level of the clock when no data is being sent.

CPOL Clock polarity

0: Clock is *LOW* when idle.

1: Clock is *HIGH* when idle.

CPHA Clock phase

That clock edge used to read the data bit.

0: Data sampled on the 1st clock edge (*the leading edge*).

1: Data sampled on the 2nd clock edge (*the trailing edge*).



Transmission Example

one main, two subs

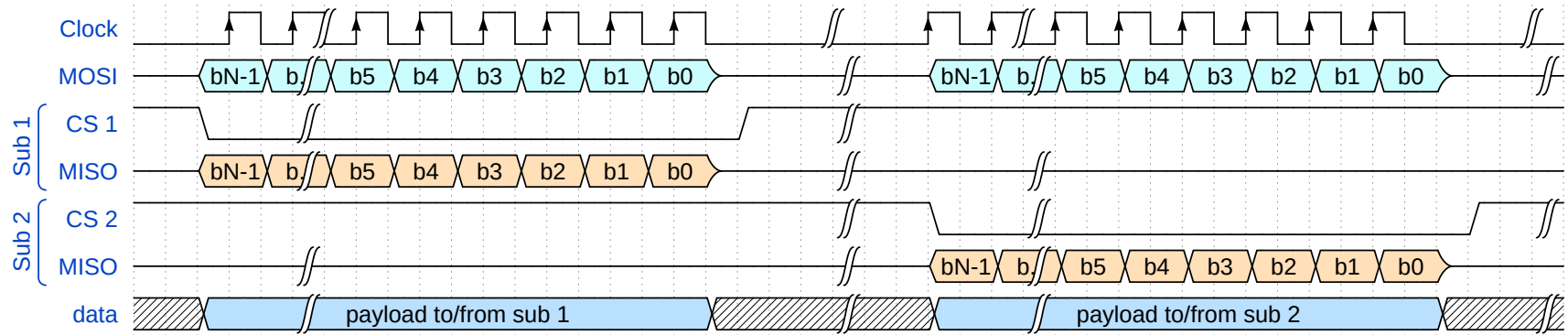

1. **main** activates the CS pin of **sub 1**
2. **main** writes the first bit on MOSI, **sub 1** writes the first bit on MISO
3. **main** starts the clock
4. **main** and **sub 1** send the rest of the bits
5. **main** stops the clock
6. **main** deactivates the CS pin of **sub 1**
7. **main** activates the CS pin of **sub 2**
8. **main** writes the first bit on MOSI, **sub 2** writes the first bit on MISO
9. **main** starts the clock
10. **main** and **sub 2** send the rest of the bits
11. **main** stops the clock
12. **main** deactivates the CS pin of **sub 2**



Daisy Chaining

using several SPI devices together

1. **main** activates all the **subs**
2. on the clock edge
 - **main** sends data to **sub 1**
 - **sub 1** sends data to **sub 2**
 - ...
 - **sub n-1** sends data to **sub n**
 - **sub n** sends data to **main**

1. usually **subs** send the previous data bit received from **main** to the **next sub** ←

activate all the **sub** devices

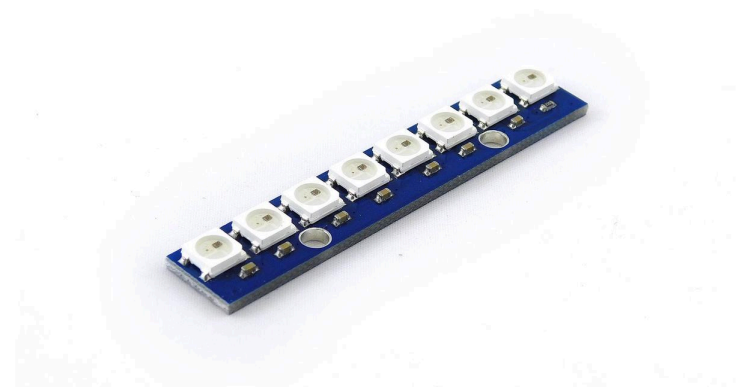
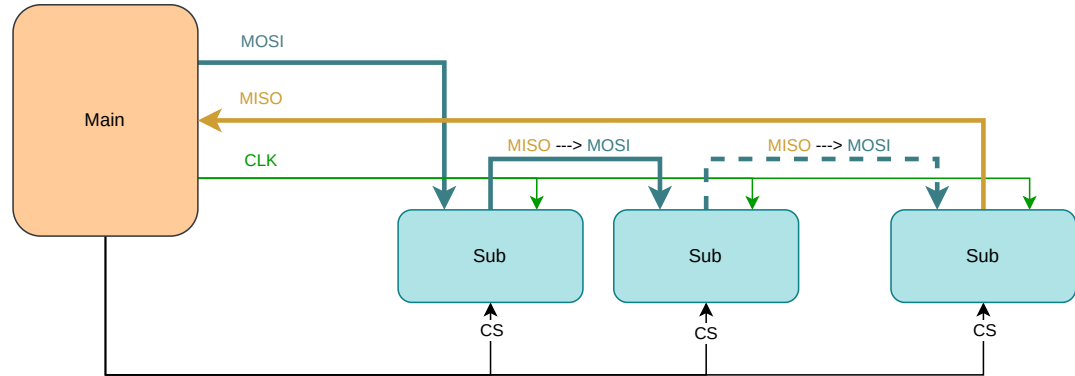

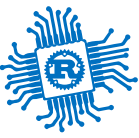

Facts

Transmission	<i>duplex</i>	data must be sent in both directions at the same time
Clock	<i>synchronized</i>	the main and sub use the same clock, there is no need for clock synchronization
Wires	<i>MISO / MOSI / CLK / CS</i>	different read and write wires, a clock wire and an <i>optional</i> chip select wire for every sub
Devices	<i>1 main several subs</i>	a receiver and a transmitter
Speed	<i>no limit</i>	does not have any limit, it is limited by the main clock and the electronics wirings

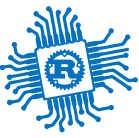

Usage

- EEPROMs / Flash (usually in *QSPI* mode)
 - Raspberry Pi Pico has its 2MB Flash connected using *QSPI*
- sensors / small displays
- RP2350 has two SPI devices
- STM32U545RE has two full SPI devices and one limited SPI device

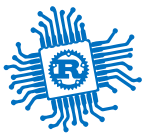

Synchronous Embassy API - RP2350

```
pub struct Config {  
    pub frequency: u32,  
    pub phase: Phase,  
    pub polarity: Polarity,  
}
```

```
pub enum Phase {  
    CaptureOnFirstTransition,  
    CaptureOnSecondTransition,  
}
```

```
pub enum Polarity {  
    IdleLow,  
    IdleHigh,  
}
```

```
1 use embassy_rp::spi::Config as SpiConfig;  
2 let mut config = SpiConfig::default();  
3 config.frequency = 2_000_000;  
4  
5 let miso = p.PIN_12;  
6 let mosi = p.PIN_11;  
7 let clk = p.PIN_10;  
8 let mut spi = Spi::new_blocking(p.SPI1, clk, mosi, miso, config);  
9  
10 // Configure CS  
11 let mut cs = Output::new(p.PIN_X, Level::High);  
12  
13 cs.set_low();  
14 let mut buf = [0x90, 0x00, 0x00, 0xd0, 0x00, 0x00];  
15 spi.blocking_transfer_in_place(&mut buf);  
16 cs.set_high();
```



Synchronous Embassy API - STM32U545RE

```
pub struct Config {  
    pub mode: Mode,  
    pub bit_order: BitOrder,  
    pub frequency: Hertz,  
    pub miso_pull: Pull,  
    pub gpio_speed: Speed,  
}
```

```
pub struct Mode {  
    pub polarity: Polarity,  
    pub phase: Phase,  
}  
  
pub enum Polarity {  
    IdleLow, IdleHigh,  
}
```

```
pub enum Phase {  
    CaptureOnFirstTransition,  
    CaptureOnSecondTransition,  
}  
  
pub enum BitOrder {  
    LsbFirst, MsbFirst,  
}
```

```
pub enum Speed { Low,  
                 Medium, High, VeryHigh,  
}
```

```
1 use embassy_stm32::spi::Config as SpiConfig;  
2 let mut config = SpiConfig::default();  
3 config.frequency = Hertz(1_000_000);  
4  
5 let miso = p.PA6;  
6 let mosi = p.PA7;  
7 let clk = p.PA5;  
8 let mut spi = Spi::new_blocking(p.SPI1, clk, mosi, miso, config);  
9  
10 // Configure CS  
11 let mut cs = Output::new(p.PXn, Level::High, Speed::Low);  
12  
13 cs.set_low();  
14 let mut buf = [0x90, 0x00, 0x00, 0xd0, 0x00, 0x00];
```



Asynchronous Embassy API

for RP2040

```
1 use embassy_rp::spi::Config as SpiConfig;
2 let mut config = SpiConfig::default();
3 config.frequency = 1_000_000;
4
5 let miso = p.PIN_12;
6 let mosi = p.PIN_11;
7 let clk = p.PIN_10;
8 let mut spi = Spi::new(p.SPI1, clk, mosi, miso, p.DMA_CH0, p.DMA_CH1, config);
9
10 // Configure CS
11 let mut cs = Output::new(p.PIN_X, Level::High);
12
13 cs.set_low();
14 let tx_buf = [1_u8, 2, 3, 4, 5, 6];
15 let mut rx_buf = [0_u8; 6];
16 spi.transfer(&mut rx_buf, &tx_buf).await;
17 cs.set_high();
```

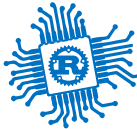

Asynchronous Embassy API

for STM32U545RE

```
1 use embassy_stm32::spi::Config as SpiConfig;
2 let mut config = SpiConfig::default();
3 config.frequency = Hertz(1_000_000);
4
5 let miso = p.PIN_12;
6 let mosi = p.PIN_11;
7 let clk = p.PIN_10;
8 let mut spi = Spi::new(p.SPI1, clk, mosi, miso, p.GPDMA1_CH0, p.GPDMA1_CH1, config);
9
10 // Configure CS
11 let mut cs = Output::new(p.PIN_X, Level::High, Speed::Low);
12
13 cs.set_low();
14 let tx_buf = [1_u8, 2, 3, 4, 5, 6];
15 let mut rx_buf = [0_u8; 6];
16 spi.transfer(&mut rx_buf, &tx_buf).await;
17 cs.set_high();
```

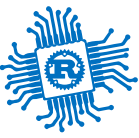

Sensors

Analog and Digital Sensors

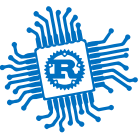

Bibliography

for this section

BOSCH, *BMP280 Digital Pressure Sensor*

- Chapter 3 - *Functional Description*
- Chapter 4 - *Global memory map and register description*
- Chapter 5 - *Digital Interfaces*
 - Subchapter 5.3 - *SPI Interface*



Sensors

analog and digital

Analog

- only the transducer (the analog sensor)
- outputs (usually) voltage
- requires:
 - an ADC to be read
 - cleaning up the noise

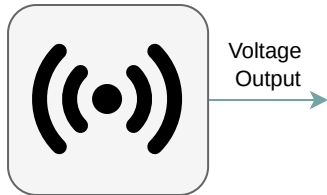

Digital

- consists of:
 - a transducer (the analog sensor)
 - an ADC
 - an MCU for cleaning up the noise
- outputs data using a digital bus

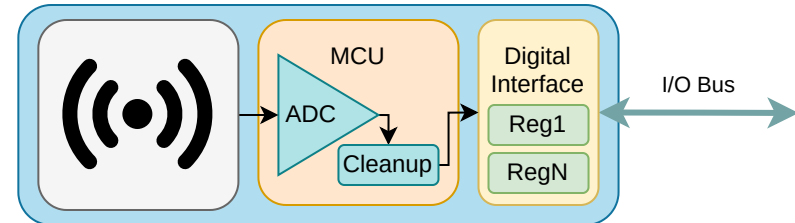



BMP280 Digital Pressure Sensor

schematics

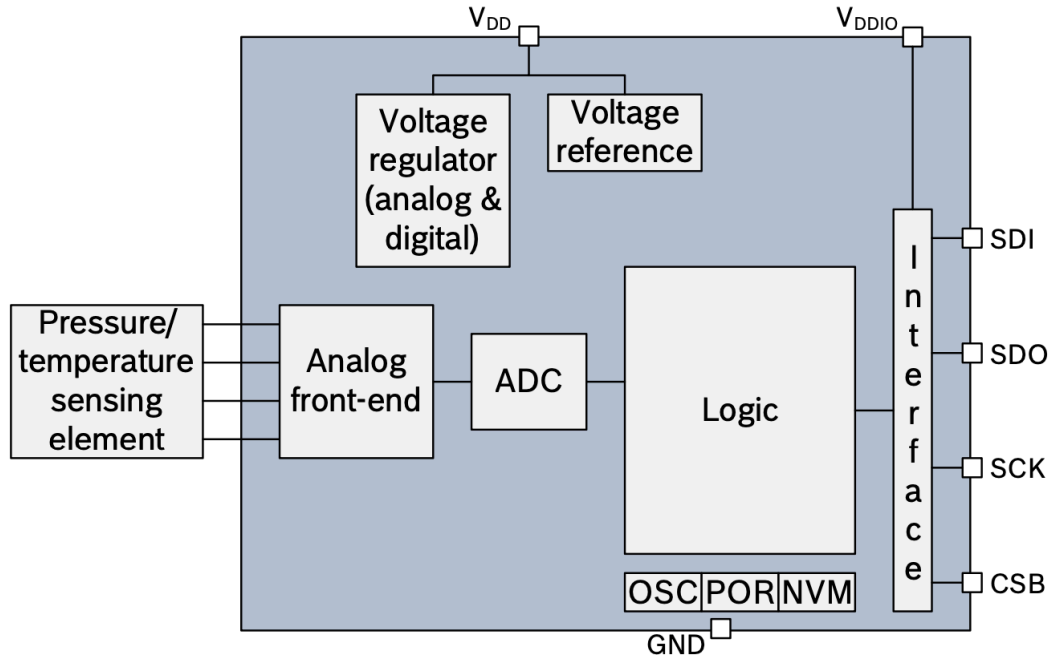

[Datasheet](#)

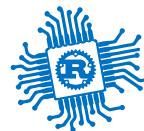

BMP280 Digital Pressure Sensor

registers map

Register Name	Address	bit7	bit6	bit5	bit4	bit3	bit2	bit1	bit0	Reset state	
temp_xlsb	0xFC	temp_xlsb<7:4>				0	0	0	0	0x00	
temp_lsb	0xFB	temp_lsb<7:0>									0x00
temp_msb	0xFA	temp_msb<7:0>									0x80
press_xlsb	0xF9	press_xlsb<7:4>				0	0	0	0	0x00	
press_lsb	0xF8	press_lsb<7:0>									0x00
press_msb	0xF7	press_msb<7:0>									0x80
config	0xF5	t_sb[2:0]			filter[2:0]			spi3w_en[0]		0x00	
ctrl_meas	0xF4	osrs_t[2:0]			osrs_p[2:0]			mode[1:0]		0x00	
status	0xF3					measuring[0]		im_update[0]		0x00	
reset	0xE0	reset[7:0]									0x00
id	0xD0	chip_id[7:0]									0x58
calib25...calib00	0xA1...0x88	calibration data									individual

Registers:	Reserved registers	Calibration data	Control registers	Data registers	Status registers	Revision	Reset
Type:	do not write	read only	read / write	read only	read only	read only	write only

Datasheet

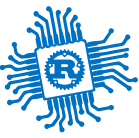

Reading from a digital sensor

using synchronous/asynchronous SPI to read the `press_lsb` register of BMP280

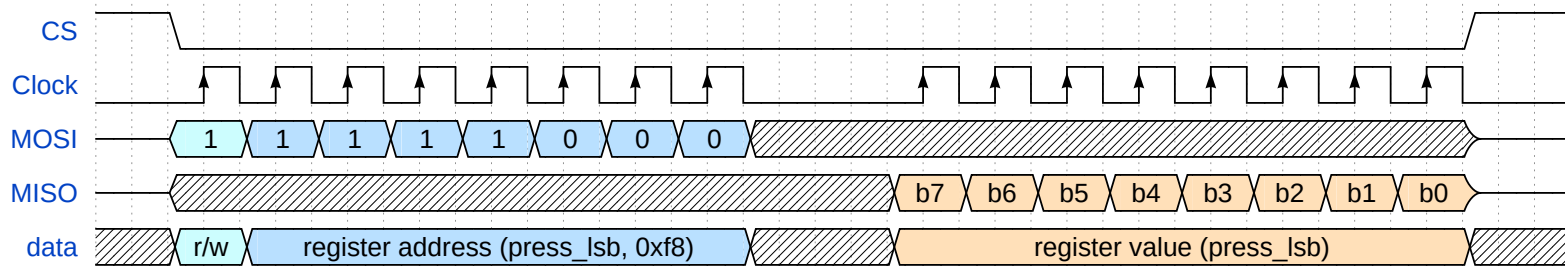

```
1  const REG_ADDR: u8 = 0xf8;
2
3  // enable the sensor
4  cs.set_low();
5
6  // buffer[2]: the address and "empty" value
7  let mut buf = [(1 << 7) | reg, 0x00];
8  spi.blocking_transfer_in_place(&mut buf);
9
10 // disable the sensor
11 cs.set_high();
12
13 // use the value
14 let pressure_lsb = buf[1];
```

```
1  const REG_ADDR: u8 = 0xf8;
2
3  // enable the sensor
4  cs.set_low();
5
6  // two buffers[2], writing and reading
7  let tx_buf = [(1 << 7) | REG_ADDR, 0x00];
8  let mut rx_buf = [0u8; 2];
9  spi.transfer(&mut rx_buf, &tx_buf).await;
10
11 // disable the sensor
12 cs.set_high();
13
```



Writing to a digital sensor

using synchronous/asynchronous SPI to set up the `ctrl_meas` register of the BMP280 sensor

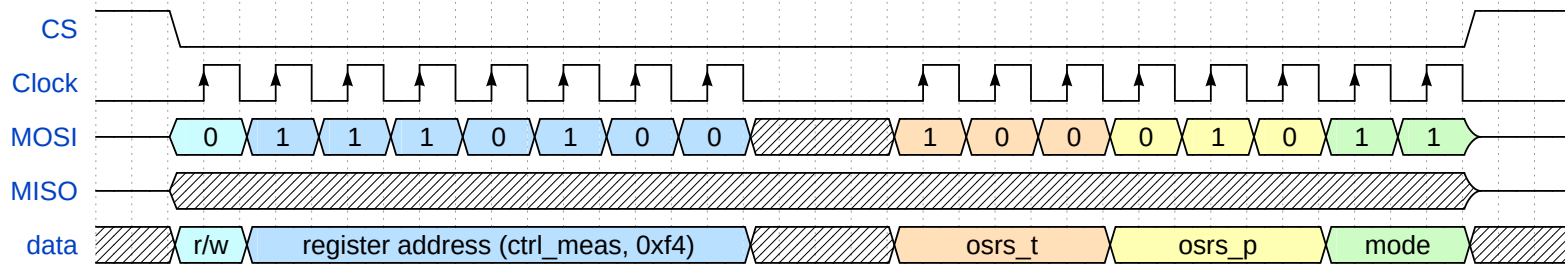

```
1  const REG_ADDR: u8 = 0xf4;
2
3  // see subchapters 3.3.2, 3.3.1 and 3.6
4  let value = 0b100_010_11;
5
6  // enable the sensor
7  cs.set_low();
8
9  // buffer[2]: the address and "empty" value
10 let mut buf = [!(1 << 7) & reg, value];
11 spi.blocking_transfer_in_place(&mut buf);
12
13 // disable the sensor
14 cs.set_high();
```

```
1  const REG_ADDR: u8 = 0xf4;
2
3  // see subchapters 3.3.2, 3.3.1 and 3.6
4  let value = 0b100_010_11;
5
6  // enable the sensor
7  cs.set_low();
8
9  // two buffers[2], writing and reading (ignored)
10 let tx_buf = [!(1 << 7) & REG_ADDR, value];
11 let mut rx_buf = [0u8; 2];
12 spi.transfer(&mut rx_buf, &tx_buf).await;
13
```

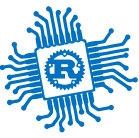

Conclusion

we talked about

- Direct Memory Access
- Buses
 - Universal Asynchronous Receiver and Transmitter
 - Serial Peripheral Interface
- Analog and Digital Sensors